

ONKYO® SERVICE MANUAL

Stereo Power Amplifier MODEL M-5300, M-5100

UD	120V AC, 60Hz
----	---------------

SAFETY-RELATED COMPONENT WARNING!!

COMPONENTS IDENTIFIED BY MARK Δ ON THE SCHEMATIC DIAGRAM AND IN THE PARTS LIST ARE CRITICAL FOR RISK OF FIRE AND ELECTRIC SHOCK. REPLACE THESE COMPONENTS WITH ONKYO PARTS WHOSE PARTS NUMBERS APPEAR AS SHOWN IN THIS MANUAL.

MAKE LEAKAGE-CURRENT OR RESISTANCE MEASUREMENTS TO DETERMINE THAT EXPOSED PARTS ARE ACCEPTABLY INSULATED FROM THE SUPPLY CIRCUIT BEFORE RETURNING THE APPLIANCE TO THE CUSTOMER.

TABLE OF CONTENTS

Specifications	2
Block diagram	2
Adjustment procedures	3
Chassis-exploded view	4
Precautions	6
Packing parts list	6
Printed board parts list	7
Printed board view	9
Schematic diagram	11



A B C D E F G

SCHEMATIC DIAGRAM MODEL M-5300

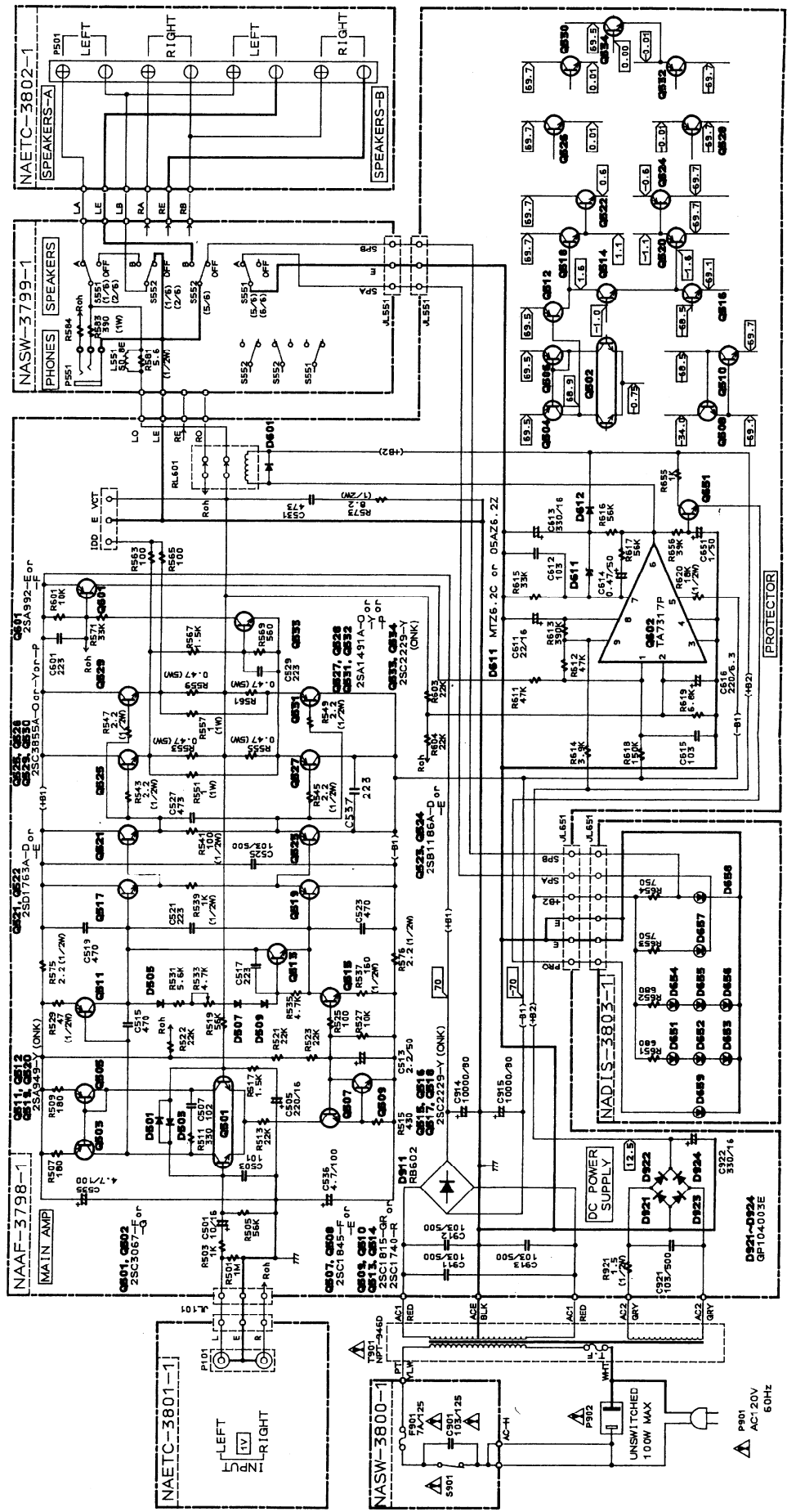

- [NOTE]**
- THE COMPONENTS IDENTIFIED BY MARK Δ ARE CRITICAL FOR SAFETY.
 - REFERENCE TO PART NUMBER SPECIFIED VOLTAGE (NO INPUT SIGNAL)
 - VOLTAGE MEASURED WITH POWER OFF
 - ALL PNP TRANSISTORS ARE EQUIVALENT TO 2SA1015-GR UNLESS OTHERWISE NOTED.
 - ALL NPN TRANSISTORS ARE EQUIVALENT TO 2SC1815-GR UNLESS OTHERWISE NOTED.
 - ALL DIODES ARE EQUIVALENT TO 1S5133 UNLESS OTHERWISE NOTED.
 - ELECTROLYTIC CAPACITORS (#) ARE IN μ F/WV.
 - ALL CAPACITORS ARE IN pF/50MV UNLESS OTHERWISE NOTED.
 - EX33P-030, 33P-F-330, 330P-F-331, 0.033P-F-333
 - ALL RESISTORS ARE IN OHMS 1/4 WATTS UNLESS OTHERWISE NOTED.
 - THE THICK LINES IN PC BOARD ARE THE PRINTING SIDE OF THE PARTS.
 - **[REVISION]**
 - CIRCUIT IS SUBJECT TO CHANGE FOR IMPROVEMENT.

D851-0858
D859
SEL2213C
D857, D858 (CG) or (DO)
SEL2413E (CG) or (DO)

D821-0824
GF10-003E

SPECIFICATIONS

	M-5300	M-5100
Power Output:	150 watts per channel, min. RMS, at 8 ohms, both channels driven, from 20Hz to 20kHz, with no more than 0.09% THD	110 watts per channel, min. RMS, at 8 ohms, both channels driven, from 20Hz to 20kHz, with no more than 0.09% THD
Total Harmonic Distortion:	0.09% at 150 watts	0.09% at 110 watts
IM Distortion:	0.09% at 150 watts	0.09% at 110 watts
Damping Factor:	40 at 8 ohms	40 at 8 ohms
Frequency Response:	5 - 100kHz \pm 1dB	5 - 100kHz \pm 1dB
Sensitivity and Impedance:	1V/50kohms	1V/50kohms
Signal to Noise Ratio:	100dB (IHFA-202 1 watt output)	100dB (IHFA-202 1 watt output)
General		
Power Supply:	AC120V, 60Hz	AC120V, 60Hz
Dimensions (W x H x D):	435 x 158 x 289.5mm 17-1/8" x 6-1/4" x 11-3/8"	435 x 158 x 289.5mm 17-1/8" x 6-1/4" x 11-3/8"
Weight:	9.1kg, 20.1 lbs.	8.1kg, 17.9 lbs.

Specifications and features are subject to change without notice.

BLOCK DIAGRAM

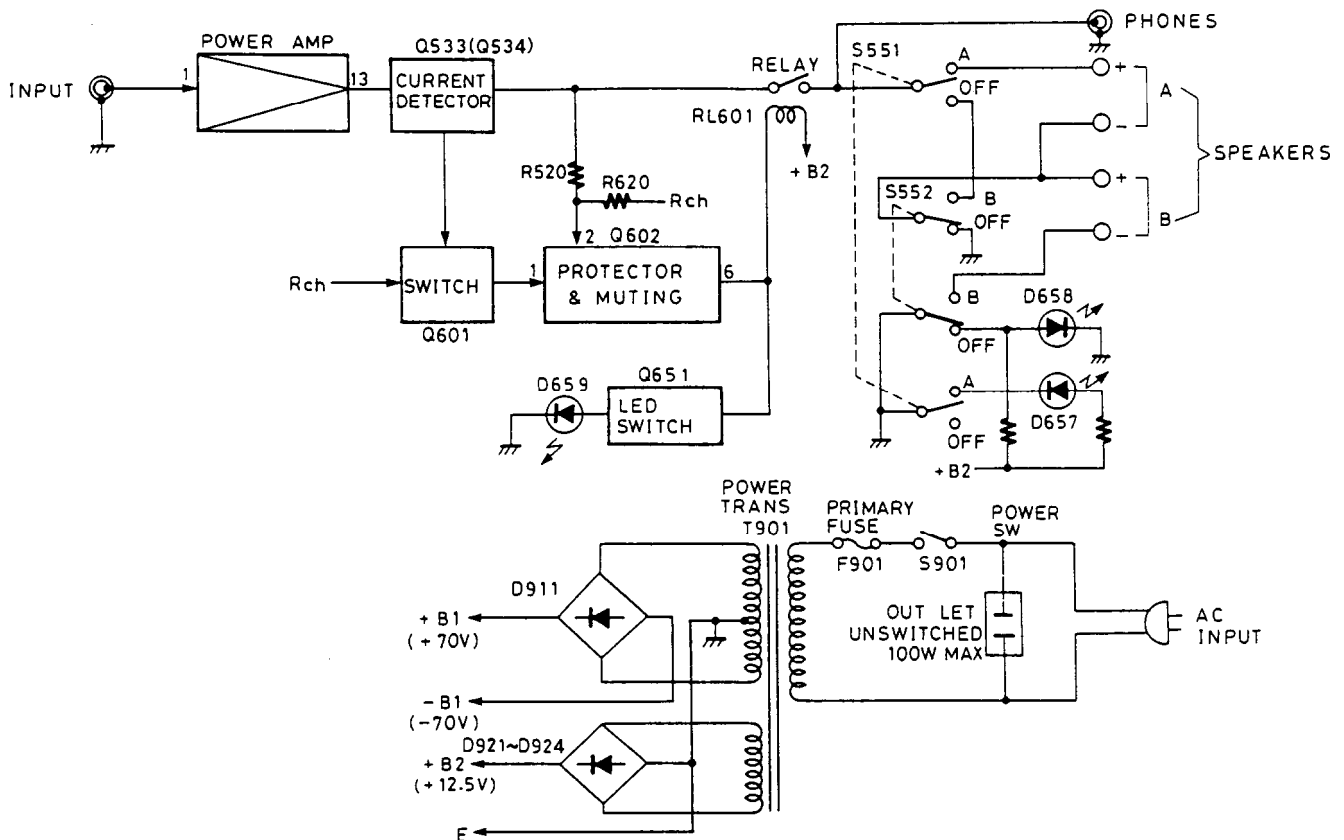

ADJUSTMENT PROCEDURES

Adjustments and Checking the Protection Circuitry

1. Preparations

- 1) Place the unit on the workbench. (There should be about 15 mm of space between the base plate of the unit and the work surface.)
- 2) Set up the unit as follows.
 - (1) No load
 - (2) No signal
 - (3) Volume turned all the way down
 - (4) Speaker switch OFF
 - (5) Power switch OFF

Note) Check the following points before making adjustments

- (1) The power switch should be OFF.
- (2) The interior of the unit should not be warm.

2. Idling current adjustment

- 1) Turn the power switch ON and allow the unit to warm up for about 10 minutes.
 - (1) Adjust R533 (R634) so that the voltage at test point VCT-IID on the NAAF-3798 circuit board is $10\text{mV} \pm 5\text{mV}$.
- Note) Semi-fixed resistors enclosed in parentheses () are for the right channel.

3. Check of operation of protection circuitry

- 1) Check of operation of protection relay
 - (1) Confirm that the relay turns ON approximately 6 seconds after the power switch is turned ON.
 - (2) The SERVO indicator LED should light at the same time.
 - (3) The relay should turn OFF approximately 0.5 seconds after the power switch is turned OFF.
 - 2) Check of DC detection and servo circuitry operation
 - (1) Turn the power on with no load.
 - (2) After the speaker relay turns ON, apply DC+ 1.5 V to the CD input terminals. Confirm that the relay turns OFF.
 - (3) Confirm that operation is the same as (2) above when an input of DC-1.5 V is applied.
- Note) Under no circumstances connect a load or short the speaker terminals when performing the above test.
- 3) Signal input from the circuit illustrated below with no load.
 - (1) Confirm that when a 1 ohm load is connected the speaker relay switchse OFF and ON a couple of times and then stays OFF.

Note) The period before that relay stays OFF should not last for more than 1 minute.

Relay OFF status can be canceled by switching the power OFF.

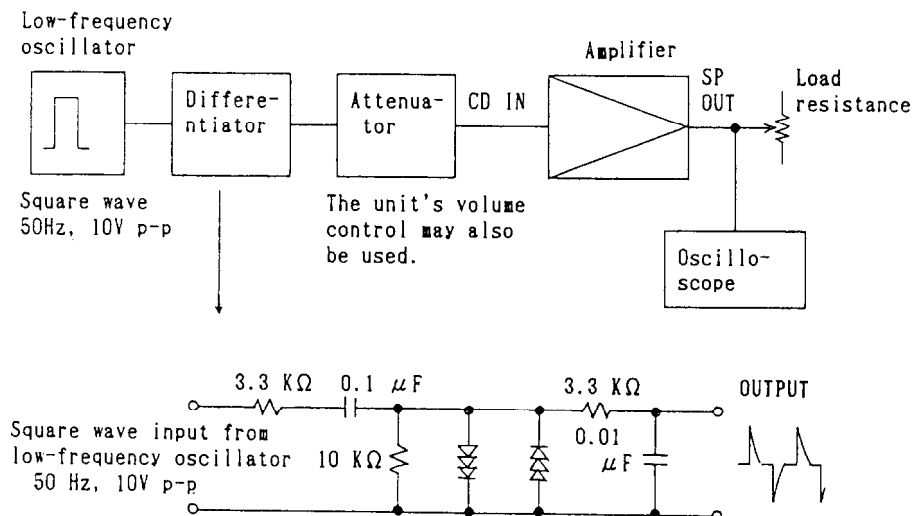

CHASSIS-EXPLODED VIEW

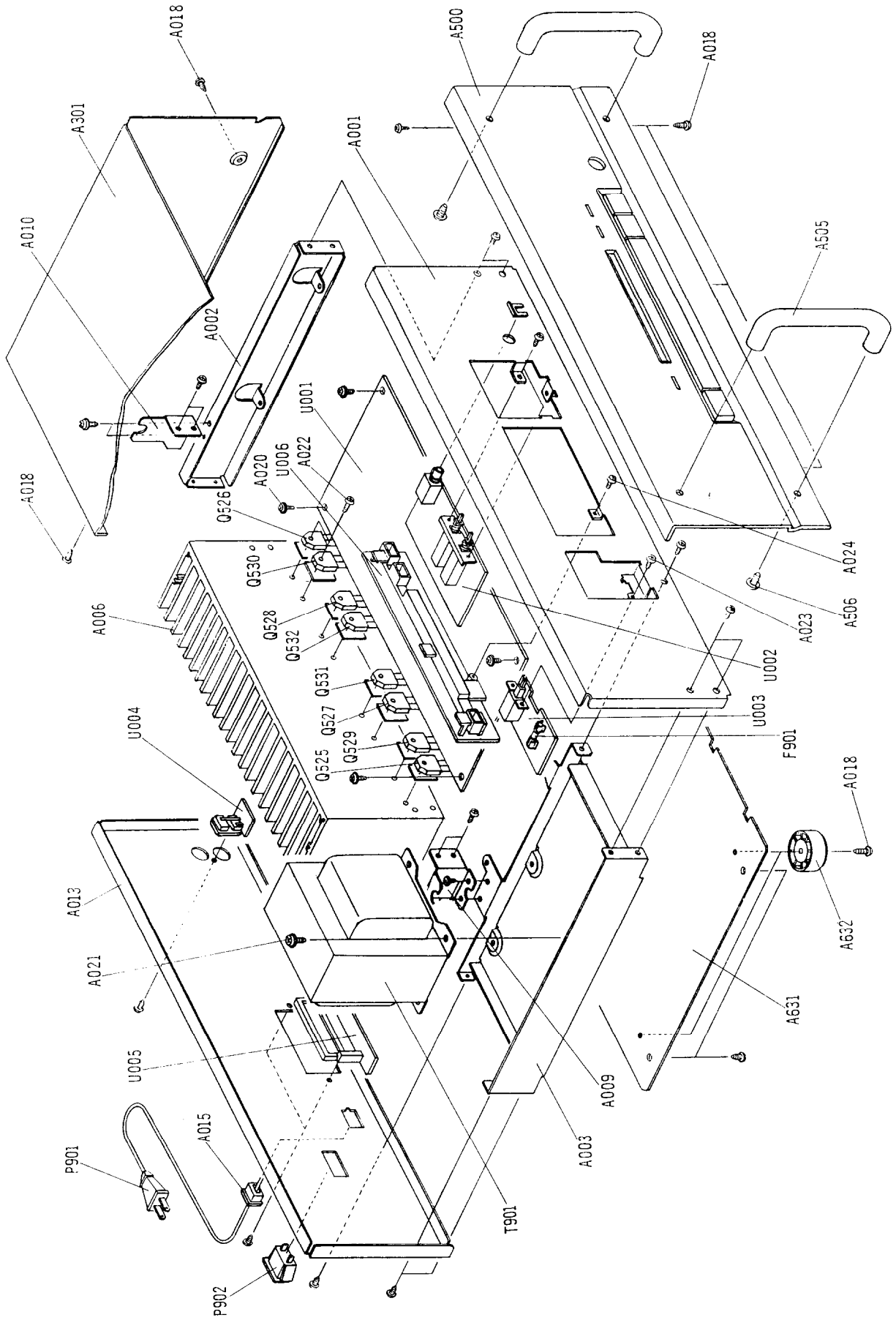

CHASSIS-EXPLODED VIEW-PARTS LIST

M-5300			M-5100		
REF NO.	PART NO.	DESCRIPTION	REF.NO.	PART NO.	DESCRIPTION
A001	27110550A	FRONT BRACKET	A001	27110550A	FRONT BRACKET
A002	27115221-1	SIDE BRACKET	A002	27115221-1	SIDE BRACKET
A003	27130604A	BRACKET (PT)	A003	27130604A	BRACKET (PT)
A006	27160251	HEATSINK	A006	27160252	HEATSINK
A009	27141020E	BRACKET (HE)	A009	27141020E	BRACKET (HE)
A010	27141020-1A	BRACKET (HE)	A010	27141020-1A	BRACKET (HE)
A013	27121328A	BACK PANEL	A013	27121333A	BACK PANEL
A015	27300750	BUSHING (CORD)	A015	27300750	BUSHING (CORD)
A018	834430088	3TTS+8BBC, TAP-TIGHT SCREW	A018	834430088	3TTS+8BBC, TAP-TIGHT SCREW
A020	831130088	3TTW+8B, TAP-TIGHT SCREW	A020	831130088	3TTW+8B, TAP-TIGHT SCREW
A021	830440089	4TTC+8CBC, TAP-TIGHT SCREW	A021	830440089	4TTC+8CBC, TAP-TIGHT SCREW
A022	801433	3SMS10WSW+14BBC, SPECIAL TAP-TIGHT SCREW	A022	801433	3SMS10WSW+14BBC, SPECIAL TAP-TIGHT SCREW
A023	82143006	3P+6FNBC, PAN HEAD SCREW	A023	82143006	3P+6FNBC, PAN HEAD SCREW
A024	833430080	3TTP+8PBC, TAP-TIGHT SCREW	A024	833430080	3TTP+8PBC, TAP-TIGHT SCREW
A301	28184451	TOP COVER	A301	28184451	TOP COVER
A500	1A212121	FRONT PANEL	A500	1A213121	FRONT PANEL
(A504)	28198672A	PACKET (SP)	(A504)	28198672A	PACKET (SP)
(A801)	28323944A	KNOB ASS'Y (GUIDE)	(A801)	28323944A	KNOB ASS'Y (GUIDE)
A631	27170266B	BOTTOM BOARD	A631	27170266B	BOTTOM BOARD
A632	27175153-1	BOTTOM LEG	A632	27175153-1	BOTTOM LEG
A505	28158035	HANDLE	A505	28158035	HANDLE
A506	830440109	4TTC+10CBC, TAP-TIGHT SCREW	A506	830440109	4TTC+10CBC, TAP-TIGHT SCREW
Q525, Q526	2202203 or	2SC3855A-O or	Q525, Q526	2202223 or	2SC3854A-O or
Q529, Q530	2202204 or	2SC3855A-Y or	Q529, Q530	2202224 or	2SC3854A-Y or
	2202206	2SC3855A-P, TRANSISTOR		2202226	2SC3854A-P, TRANSISTOR
Q527, Q528	2202213 or	2SA1491A-O or	Q527, Q528	2202233 or	2SA1490A-O or
Q531, Q532	2202214 or	2SA1491A-Y or	Q531, Q532	2202234 or	2SA1490A-Y or
	2202216	2SA1491A-P, TRANSISTOR		2202236	2SA1490A-P, TRANSISTOR
▲ T901	2300174A	NPT-946D, POWER TRANSFORMER	▲ T901	2300226	NPT-961D, POWER TRANSFORMER
▲ P901	253123 or	AS-UC-6#18, POWER SUPPLY CABLE or	▲ P901	253123 or	AS-UC-6#18, POWER SUPPLY CABLE or
	253136 or	AS-UC-6#18, POWER SUPPLY CABLE or		253136 or	AS-UC-6#18, POWER SUPPLY CABLE or
	253140 or	AS-UC-6#18, POWER SUPPLY CABLE or		253140 or	AS-UC-6#18, POWER SUPPLY CABLE or
	253146	AS-UC-6#18, POWER SUPPLY CABLE		253146	AS-UC-6#18, POWER SUPPLY CABLE
▲ P902	25050290	NSCT-2P118T, AC OUTLET	▲ P902	25050290	NSCT-2P118T, AC OUTLET
▲ F901	252052	7A(ST-6) FUSE	▲ F901	252052	7A(ST-6) FUSE
U 1	1A212598-1	NAAF-3798-1, MAIN PC BOARD ASS'Y	U 1	1A213598-2	NAAF-3798-2, MAIN PC BOARD ASS'Y
U 2	1A212599-1	NASW-3799-1, SPEAKER SWITCH PC BOARD ASS'Y	U 2	1A213599-2	NASW-3799-2, SPEAKER SWITCH PC BOARD ASS'Y
U 3	1A212500-1	NASW-3800-1, POWER SWITCH PC BOARD ASS'Y	U 3	1A213500-2	NASW-3800-2, POWER SWITCH PC BOARD ASS'Y
U 4	1A212501-1	NAETC-3801-1, INPUT TERMINAL PC BOARD ASS'Y	U 4	1A213501-2	NAETC-3801-2, INPUT TERMINAL PC BOARD ASS'Y
U 5	1A212502-1	NAETC-3802-1, SPEAKER TERMINAL PC BOARD ASS'Y	U 5	1A213502-2	NAETC-3802-2, SPEAKER TERMINAL PC BOARD ASS'Y
U 6	1A212503-1	NADIS-3803-1, DISPLAY LED PC BOARD ASS'Y	U 6	1A213503-2	NADIS-3803-2, DISPLAY LED C BOARD ASS'Y

NOTE: THE COMPONENTS IDENTIFIED BY MARK ▲ ARE CRITICAL FOR RISK OF FIRE AND ELECTRIC SHOCK. REPLACE ONLY WITH PARTS NUMBER SPECIFIED.

PRECAUTIONS

1. Replacing the fuses

For continued protection against risk fire, replace only with same type and same rating fuse.

CIRCUIT NO.	PARTS NO.	DESCRIPTION
F901	252052	7A (ST-6), Primary fuse

2. Insulation resistance measurement

Connect the insulating-resistance tester between the plug of power supply cable and the terminal GND on the back panel. Specifications; More than 10MΩ at 500V.

PACKING PARTS LIST

REF NO.	PART NO.	DESCRIPTION
A851	29052043	MASTER CARTON BOX [M5300]
A851	29052044	MASTER CARTON BOX [M5100]
A852	29091152B	PAD, LEFT
A853	29091153B	PAD, RIGHT
A855	29100033A	750 × 500mm, POLY-VINYL BAG
A856	282301	SEALING HOOK
A857	29110071-1	DAMPLON TAPE
A871	261504	PAPER TAPE
A868	29360778	LABEL (FLASH) [N]
ACCESSORY BAG ASS'Y		
A874	29341503	INSTRUCTION MANUAL
A904	29365019	WARRANTY CARD [N]
A905	29358002G	SERVICE STATION LIST [N]
A875	2010098A	CONNECTION CABLE
A870	29100006A	350 × 250mm, POLY-VINYL BAG

NOTE [N] : ONLY U.S.A. MODELS
 [M5300] : ONLY M-5300 MODELS
 [M5100] : ONLY M-5100 MODELS

PRINTED CIRCUIT BOARD—PARTS LIST**M-5300****MAIN PC BOARD (NAAF-3798-1)—PARTS LIST**

CIRCUIT NO.	PART NO.	DESCRIPTION
ICs		
Q602	222584	TA7317P
Transistors		
Q501, Q502	2213676 or 2213677	2SC3067F or 2SC3067G
Q503~Q506	2211455 or 2213074	2SA1015GR or 2SA933R
Q507, Q508	2211732 or 2211733	2SC1845F or 2SC1845E
Q509, Q510	2211255 or	2SC1815GR or
Q513, Q514	2211183	2SC1740R
Q651		
Q511, Q512	2211359	2SA949Y(ONK)
Q519, Q520		
Q515~Q518	2211639	2SC2229Y(ONK)
Q533, Q534		
Q521, Q522	2202034 or 2202035	2SD1763AD or 2SD1763AE
Q523, Q524	2202024 or 2202025	2SB1186AD or 2SB1186AE
Q601	2211793 or 2211792	2SA992E or 2SA992F
Diodes		
D501~D601	223163	1SS133
D612		
D611	224450623 or 224150623	MTZ6.2C or 05AZ6.2Z, Zener
D911	223898	PB602
D921~D924	22380035	GP104003E
Capacitors		
C501, C502	391741009	10 μ F, 16V, Elect.(HWQ)
C503, C504	372121014	100 pF, 50V, Styrene
C505, C506	354742219	220 μ F, 16V, Elect.
C507, C508	372121024	1000 pF, 50V, Styrene
C513, C514	354780229	2.2 μ F, 50V, Elect.
C527, C528	374794734	0.047 μ F, 63V, Film(TF)
C531, C532		
C535, C536	354790479	4.7 μ F, 100V, Elect.
C537, C538	374722234	0.022 μ F, 50V, Film(TF)
C611	354742209	22 μ F, 16V, Elect.
C613	354743319	330 μ F, 16V, Elect.
C614	354784799	0.47 μ F, 50V, Elect.
C616	354722219	220 μ F, 6.3V, Elect.
C651	354780109	1 μ F, 50V, Elect.
C914, C915	3504236	10000 μ F, 80V, Elect.
C922	354743319	330 μ F, 16V, Elect.
Resistors		
R529, R530	442524704	47 Ω , 1/2W, Metal oxide film
R533, R534	5210062	N06HR4.7KBD, Semi fixed
R537, R538	442521614	160 Ω , 1/2W, Metal oxide film
R539, R540	442521024	1 k Ω , 1/2W, Metal oxide film
R541, R542	442521014	100 Ω , 1/2W, Metal oxide film
R543~R550	442520224	2.2 Ω , 1/2W, Metal oxide film
R551, R552	441620104	1 Ω , 1W, Metal oxide film
R557, R558		
R553~R556	4000080 or	0.47 Ω , 5W, Metal plate or
R559~R562	4500022	0.47 Ω , 5W, Metal plate
R573, R574	442520824	8.2 Ω , 1/2W, Metal oxide film
R575, R576	442520224	2.2 Ω , 1/2W, Metal oxide film
R620	442521834	18 k Ω , 1/2W, Metal oxide film
R921	442520154	1.5 Ω , 1/2W, Metal oxide film

Heatsink
27160196

CIRCUIT NO.	PART NO.	DESCRIPTION
	Relay	
RL601	25065275	NRL-2P5A-DC12V-38
	Bracket	
	27141059	Washer

SPEAKER SWITCH CIRCUIT PC BOARD (NASW-3799-1)—PARTS LIST

CIRCUIT NO.	PART NO.	DESCRIPTION
Coils		
L551, L552	231134	S-0.8E
Resistors		
R581, R582	442520564	5.6 Ω , 1/2W, Metal oxide film
R583, R584	441623914	390 Ω , 1W, Metal oxide film
Switches		
S551, (S552)	25035620	NPS-262-L582
Headphone terminal		
P551	25045187	HLJ-0541-01-010

POWER SWITCH CIRCUIT PC BOARD (NASW-3800-1)—PARTS LIST

CIRCUIT NO.	PART NO.	DESCRIPTION
Capacitor		
Δ C901	3500065A	0.01 μ F, AC400V/125V, IS
Switch		
Δ S901	25035550	NPS-111-L512P
Fuse holders		
	250113	SN5051

INPUT TERMINAL PC BOARD (NAETC-3801-1)—PARTS LIST

CIRCUIT NO.	PART NO.	DESCRIPTION
Terminal		
P101	25045211	NPJ-2PDBL91

SPEAKER TERMINAL PC BOARD (NAETC-3802-1)—PARTS LIST

CIRCUIT NO.	PART NO.	DESCRIPTION
Terminal		
P501	25060093	NTM-8PDML34

DISPLAY LED PC BOARD (NADIS-3803-1)—PARTS LIST

CIRCUIT NO.	PART NO.	DESCRIPTION
Diodes		
D651~D656	225141	SEL2213C
D659		
D657, D658	225137CG or 225137DG	SEL2413ECG or SEL2413EDG, LED
Holder		
	27190752	Holder (LED)

NOTE: THE COMPONENTS IDENTIFIED BY MARK Δ ARE CRITICAL FOR RISK OF FIRE AND ELECTRIC SHOCK. REPLACE ONLY WITH PARTS NUMBER SPECIFIED.

PRINTED CIRCUIT BOARD—PARTS LIST

M-5100

MAIN PC BOARD (NAAF-3798-2)—PARTS LIST

CIRCUIT NO.	PART NO.	DESCRIPTION
	ICs	
Q602	222584	TA7317P
	Transistors	
Q501, Q502	2213676 or 2213677	2SC3067F or 2SC3067G
Q503~Q506	2211455 or 2213074	2SA1015GR or 2SA933R
Q507, Q508	2211732 or 2211733	2SC1845F or 2SC1845E
Q509, Q510	2211255 or	2SC1815GR or
Q513, Q514	2211183	2SC1740R
Q651		
Q511, Q512	2211353 or	2SA949O or
Q519, Q520	2211354	2SA949Y
Q515~Q518	2211633 or	2SC2229O or
Q533, Q534	2211634	2SC2229Y
Q521, Q522	2202034 or 2202035	2SD1763AD or 2SD1763AE
Q523, Q524	2202024 or 2202025	2SB1186AD or 2SB1186AE
Q601	2211793 or 2211792	2SA992E or 2SA992F
	Diodes	
D501~D601	223163	1SS133
D612		
D611	224450623 or 224150623	MTZ6.2C or 05AZ6.2Z, Zener
D911	223898	PB602
D921~D924	22380035	GP104003E
	Capacitors	
C501, C502	391741009	10 μ F, 16V, Elect.(HWQ)
C503, C504	372121014	100 pF, 50V, Styrene
C505, C506	354742219	220 μ F, 16V, Elect.
C507, C508	372121024	1000 pF, 50V, Styrene
C513, C514	354780229	2.2 μ F, 50V, Elect.
C527, C528	374794734	0.047 μ F, 63V, Film(TF)
C531, C532		
C535, C536	354790479	4.7 μ F, 100V, Elect.
C537, C538	374722234	0.022 μ F, 50V, Film(TF)
C611	354742209	22 μ F, 16V, Elect.
C613	354743319	330 μ F, 16V, Elect.
C614	354784799	0.47 μ F, 50V, Elect.
C616	354722219	220 μ F, 6.3V, Elect.
C651	354780109	1 μ F, 50V, Elect.
C914, C915	3504237	10000 μ F, 71V, Elect.
C922	354743319	330 μ F, 16V, Elect.
	Resistors	
R529, R530	442524704	47 Ω , 1/2W, Metal oxide film
R533, R534	5210062	N06HR4.7KBD, Semi fixed
R537, R538	442521614	160 Ω , 1/2W, Metal oxide film
R539, R540	442521024	1 k Ω , 1/2W, Metal oxide film
R541, R542	442521014	100 Ω , 1/2W, Metal oxide film
R543~R550	442520224	2.2 Ω , 1/2W, Metal oxide film
R551, R552	441620104	1 Ω , 1W, Metal oxide film
R557, R558		
R553~R556	4000080 or	0.47 Ω , 5W, Metal plate or
R559~R562	4500022	0.47 Ω , 5W, Metal plate
R573, R574	442520824	8.2 Ω , 1/2W, Metal oxide film
R575, R576	442520224	2.2 Ω , 1/2W, Metal oxide film
R620	442521834	18 k Ω , 1/2W, Metal oxide film
R921	442520154	1.5 Ω , 1/2W, Metal oxide film
	Heatsink	
	27160196	

CIRCUIT NO.	PART NO.	DESCRIPTION
	Relay	
RL601	25065275	NRL-2P5A-DC12V-38
	Bracket	
	27141059	Washer

SPEAKER SWITCH CIRCUIT PC BOARD (NASW-3799-2)—PARTS LIST

CIRCUIT NO.	PART NO.	DESCRIPTION
	Coils	
L551, L552	231134	S-0.8E
	Resistors	
R581, R582	442520564	5.6 Ω , 1/2W, Metal oxide film
R583, R584	441623914	390 Ω , 1W, Metal oxide film
	Switches	
S551, (S552)	25035620	NPS-262-L582
	Headphone terminal	
P551	25045187	HLJ-0541-01-010

POWER SWITCH CIRCUIT PC BOARD (NASW-3800-2)—PARTS LIST

CIRCUIT NO.	PART NO.	DESCRIPTION
	Capacitor	
Δ C901	3500065A	0.01 μ F, AC400V/125V, IS
	Switch	
Δ S901	25035550	NPS-111-L512P
	Fuse holders	
	250113	SN5051

INPUT TERMINAL PC BOARD (NAETC-3801-2)—PARTS LIST

CIRCUIT NO.	PART NO.	DESCRIPTION
	Terminal	
P101	25045211	NPJ-2PDBL91

SPEAKER TERMINAL PC BOARD (NAETC-3802-2)—PARTS LIST

CIRCUIT NO.	PART NO.	DESCRIPTION
	Terminal	
P501	25060093	NTM-8PDML34

DISPLAY LED PC BOARD (NADIS-3803-1)—PARTS LIST

CIRCUIT NO.	PART NO.	DESCRIPTION
	Diodes	
D651~D656	225141	SEL2213C
D659		
D657, D658	225137CG or 225137DG	SEL2413ECG or SEL2413EDG, LED
	Holder	
	27190752	Holder (LED)

NOTE: THE COMPONENTS IDENTIFIED BY MARK Δ ARE CRITICAL FOR RISK OF FIRE AND ELECTRIC SHOCK. REPLACE ONLY WITH PARTS NUMBER SPECIFIED.

SCHEMATIC DIAGRAM MODEL M-5100

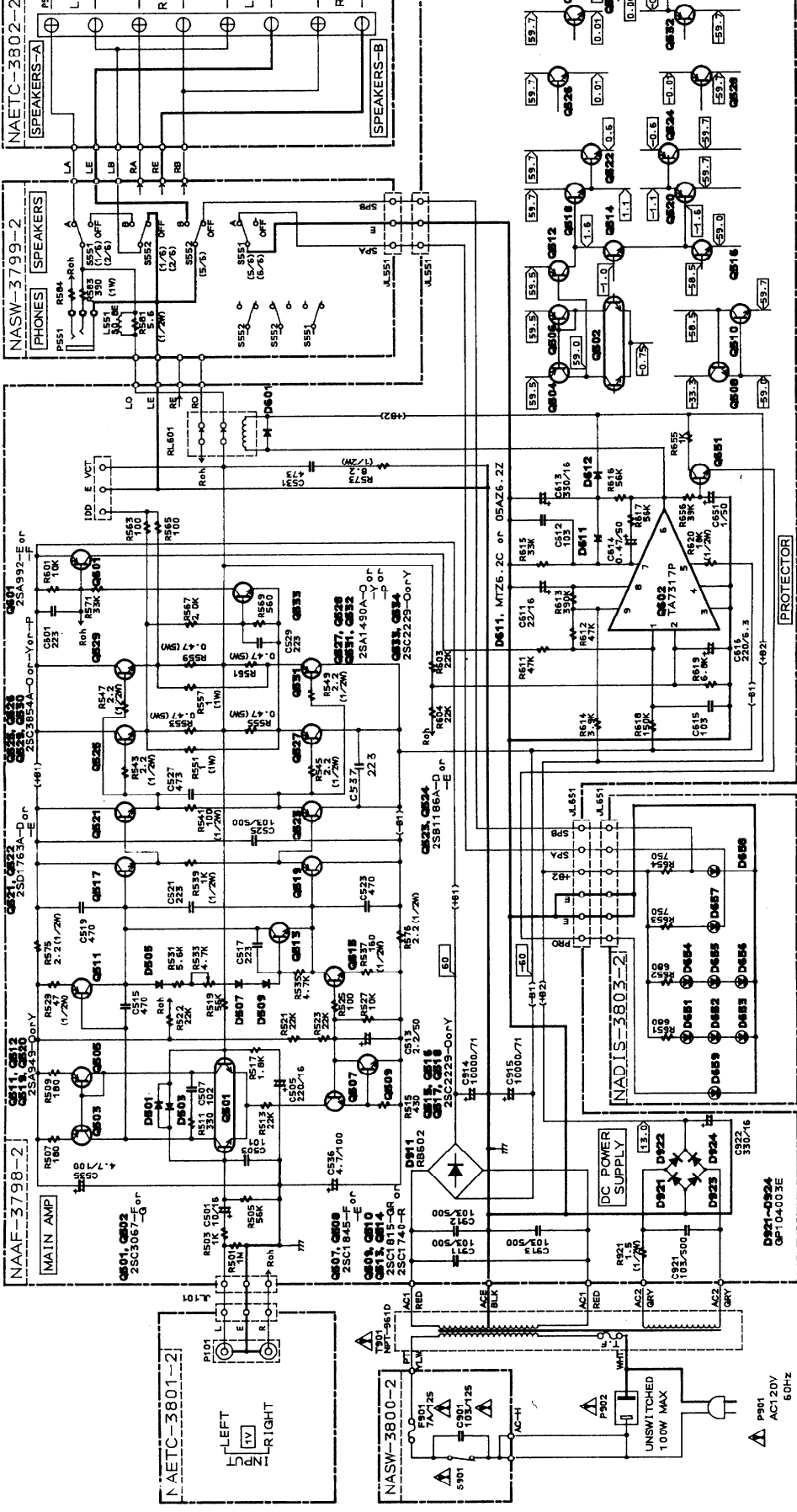

D921-D924
SEL2213C
D925, D926
SEL2413E (CG) or (DG)

NOTE

- THE COMPONENTS IDENTIFIED BY MARK \triangle ARE CRITICAL FOR SAFETY. REPLACE ONLY WITH PART NUMBER SPECIFIED.
- VOLTAGE (MEASURED WITH VOLTMETER) \square IS DC VOLTAGE. (NO INPUT SIGNAL)
- ALL PNP TRANSISTORS ARE EQUIVALENT TO 2SA1015-GR UNLESS OTHERWISE NOTED.
- ALL NPN TRANSISTORS ARE EQUIVALENT TO 2SC1619-GR UNLESS OTHERWISE NOTED.
- ALL RESISTORS ARE EQUIVALENT TO 15S133 UNLESS OTHERWISE NOTED.
- ALL CAPACITORS ARE IN P/F/50M UNLESS OTHERWISE NOTED.
- EX37BF-030, 330P-F-331, Q 033/F-333
- ALL RESISTORS ARE IN OHMS 1/4 WATTS UNLESS OTHERWISE NOTED.
- THE THICK LINES IN PC BOARD ARE THE PRINTING SIDE OF THE PARTS.
- EX: \square PRINTING SIDE
- \square CIRCUIT IS SUBJECT TO CHANGE FOR IMPROVEMENT.